

Parameter study in order to reveal critical design issues in the design for a CLC power plant using solid carbon as fuel

1st International Conference on Chemical Looping
IFP-LYON, France 17-19 March 2010

Marie Anheden, Benny Fillman, Jens Wolf
Vattenfall Research and Development AB



ECLAIR – Key objectives

- **E**mission Free **C**hemical **L**ooping Coal Combustion **P**rocess
- Demonstrate the feasibility of CLC process 1 MW pilot
- Find feasible oxygen carrier (OC),
- Verify reactor design and simulation tools,
- Conceptually specify and design equipment for emission control
- Assessment of environmental aspects of CLC technology

ECLAIR project - Partners



ECLAIR project

- Focus is set on the development of an integrated CLC power plant simulation model.

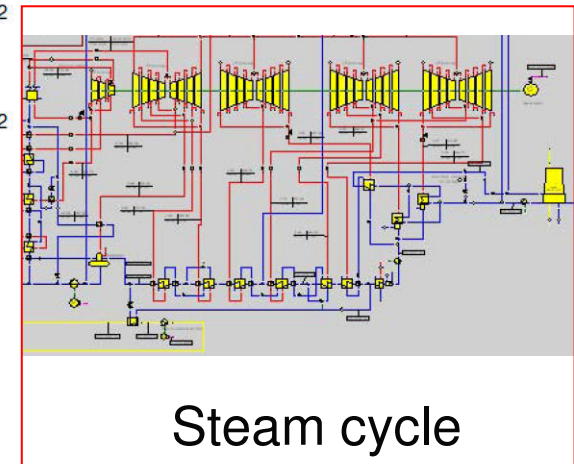
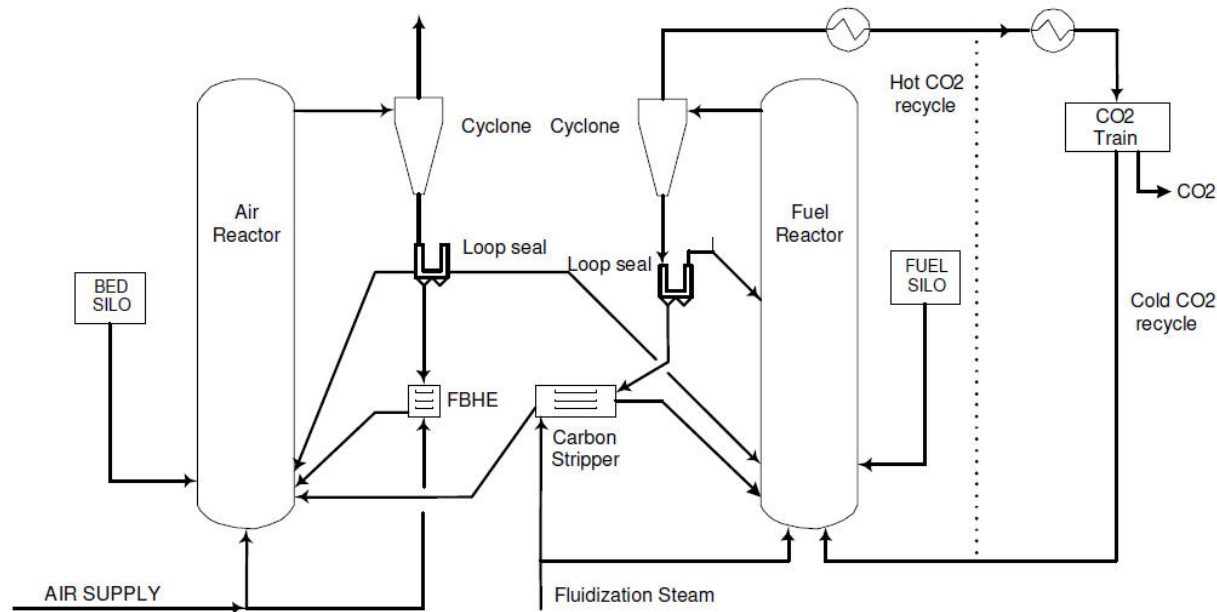

PFD adopted from ENCAP

Modeling work

- A model of the whole system has been modeled in Aspen Plus; including both CLC reactor system and steam cycle
- The model is based on:
 - heat & mass balances
 - Equilibrium and restricted equilibrium calculations are used to model chemical reactions. Reaction kinetics and hydrodynamics not included.
 - Estimations for auxiliary power consumption e.g. coal mills, coal feeding systems etc. based on existing power plants
 - Steady state

Modeling work – Sensitivity study

- The ENCAP design has been reviewed and parameters which have an impact on process characteristics and cost reduction have been identified

Fuel reactor:			
#	Description	Variation ranges (a)	Variation ranges (b)
1	Variation of (a) steam/(b) cold CO ₂ ratio recycle for fluidization.	0-90 kg/s Base case 18 kg/s	0-90 kg/s
2	Variation of (a) steam/(b) hot CO ₂ ratio recycle for fluidization.	0-90 kg/s Base case 18 kg/s	0-90 kg/s
3	(a) Coal conversion vs. (b) Carbon stripper efficiency.	70-90 % (once through)	20-90 %
Air reactor			
#	Description	Variation ranges (a)	Variation ranges (b)
1	(a) Variation of lambda value in AR vs. (b) carbon stripper efficiency	1.05-1.2	20-90%

Results

- Influence of steam/ CO2 recycle ratio and its amount

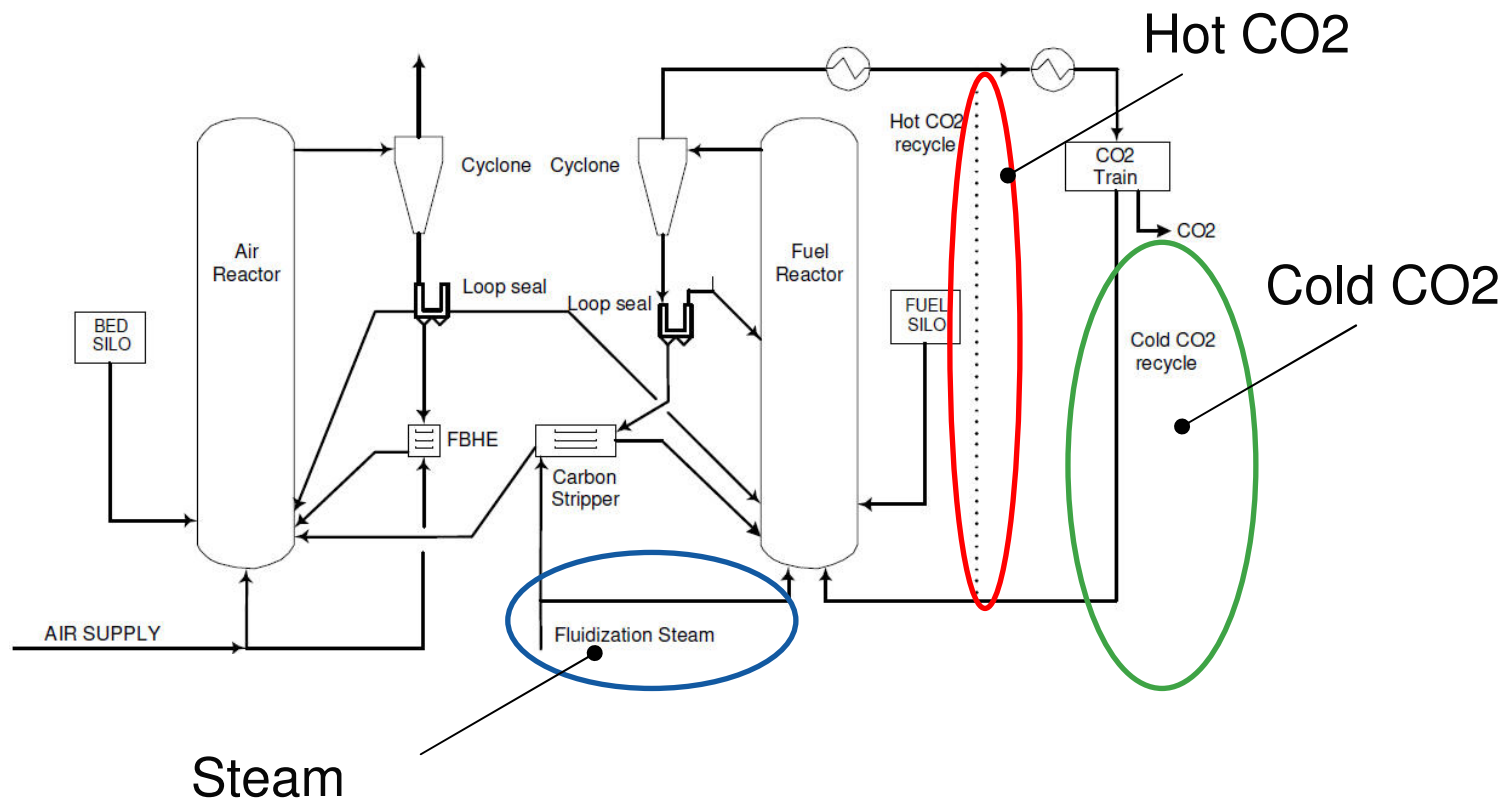

Results

Parameter Study
Influence of fluidisation media mixture and total amount on the net electrical efficiency.

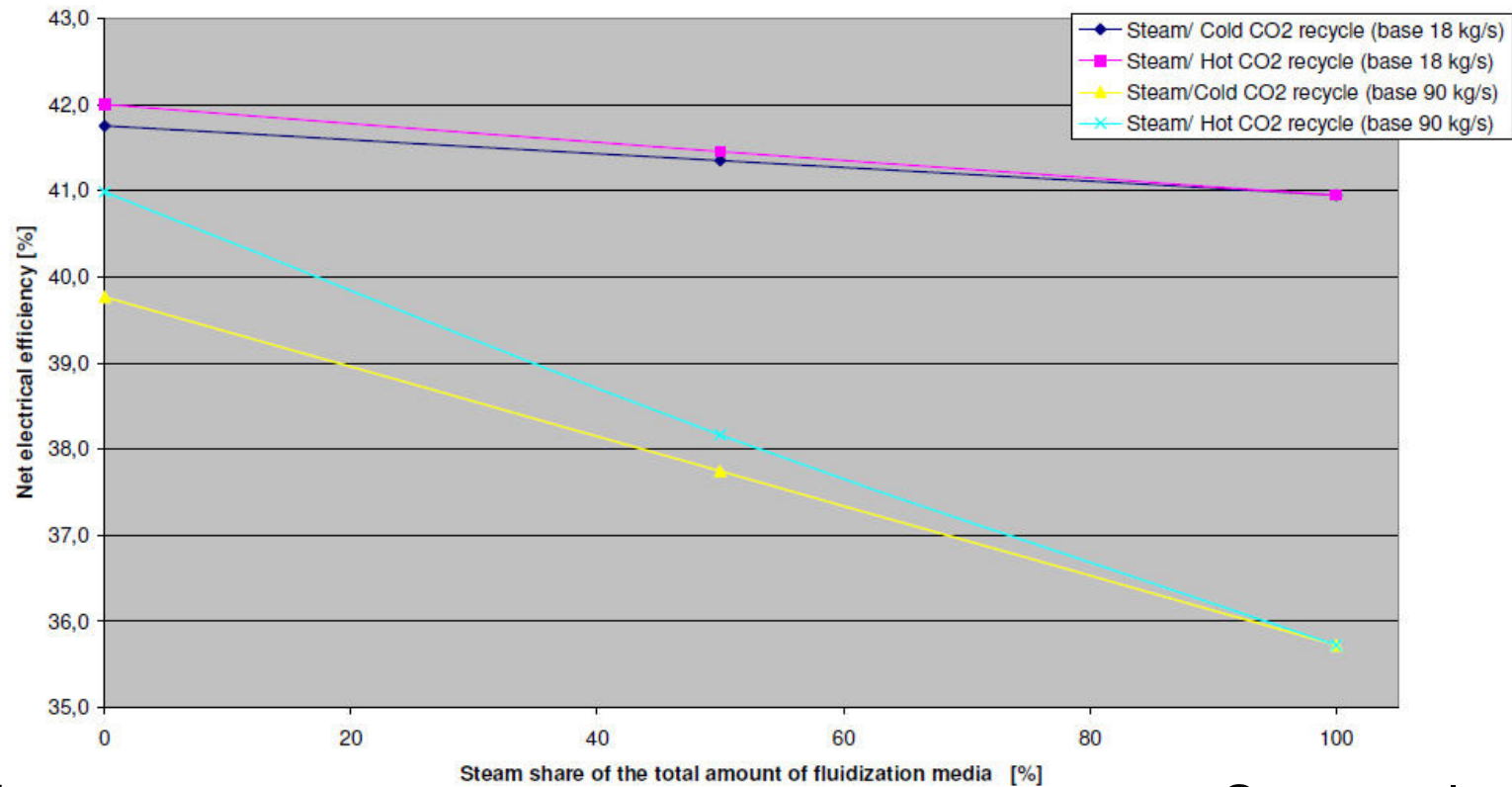

No steam

Steam only

Results

- Coal conversion vs carbon stripper efficiency

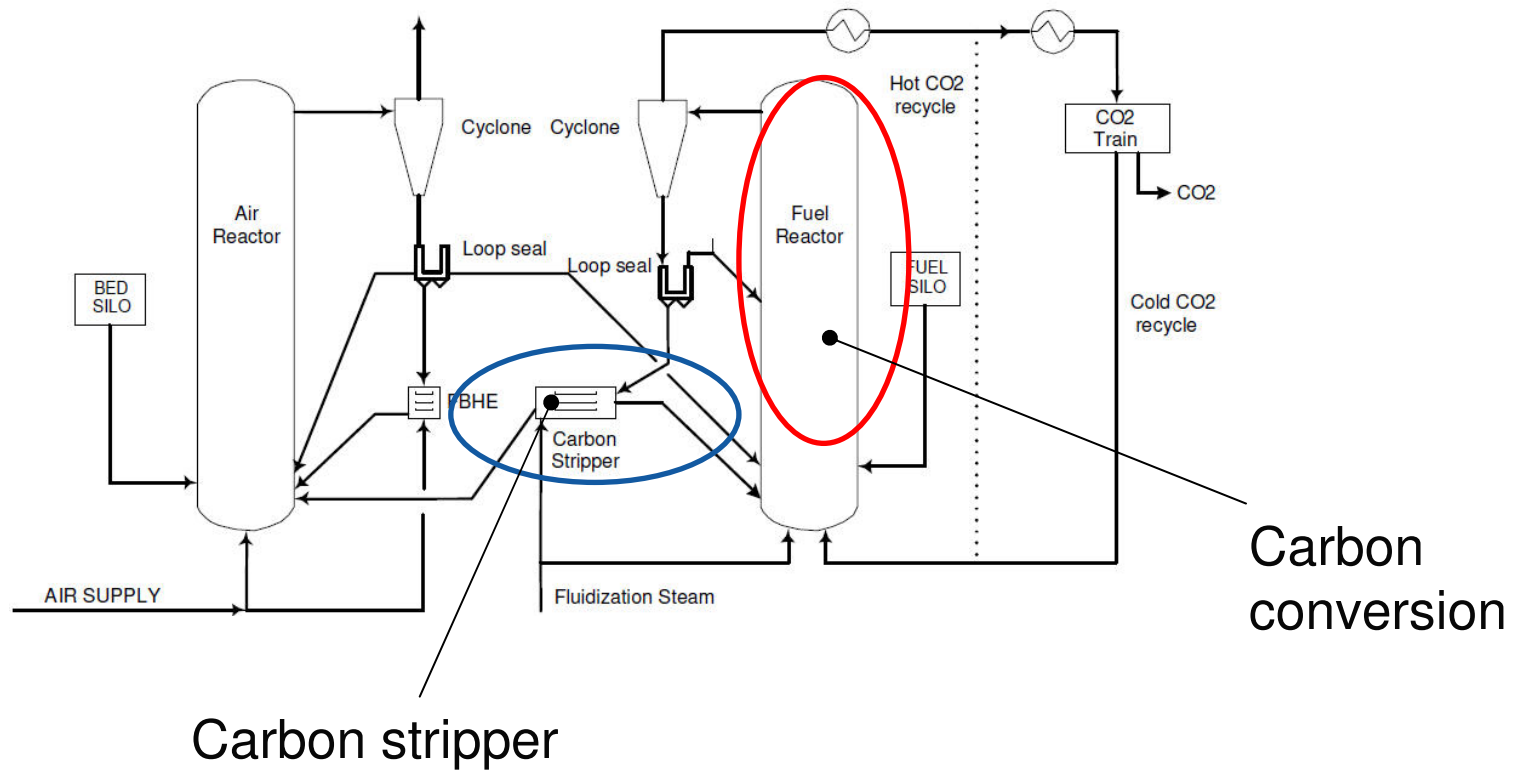

Results

Parameter Study
Carbon Conversion vs Net electrical efficiency at various Carbon Stripper efficiencies

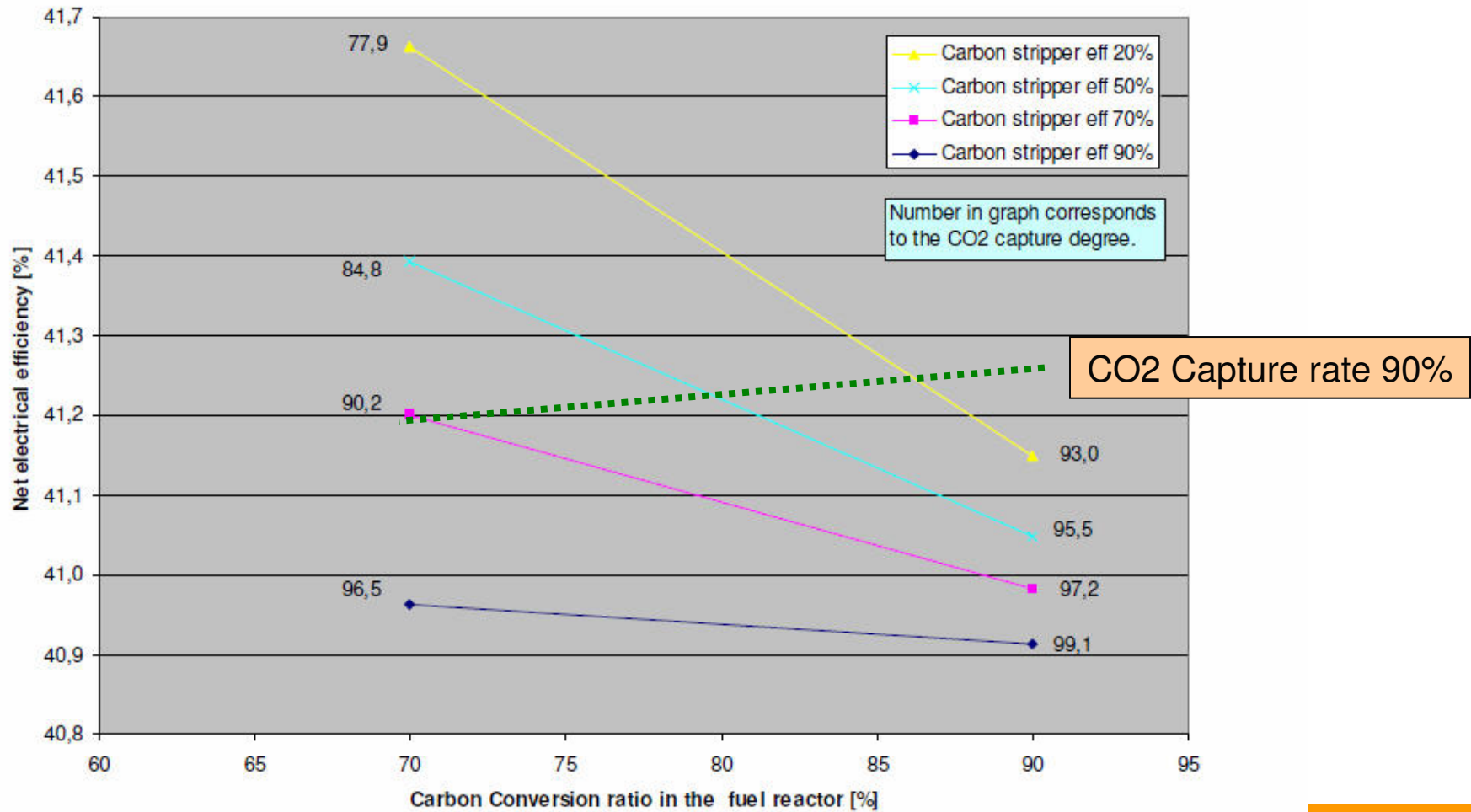

Results

- Air supply vs carbon stripper efficiency

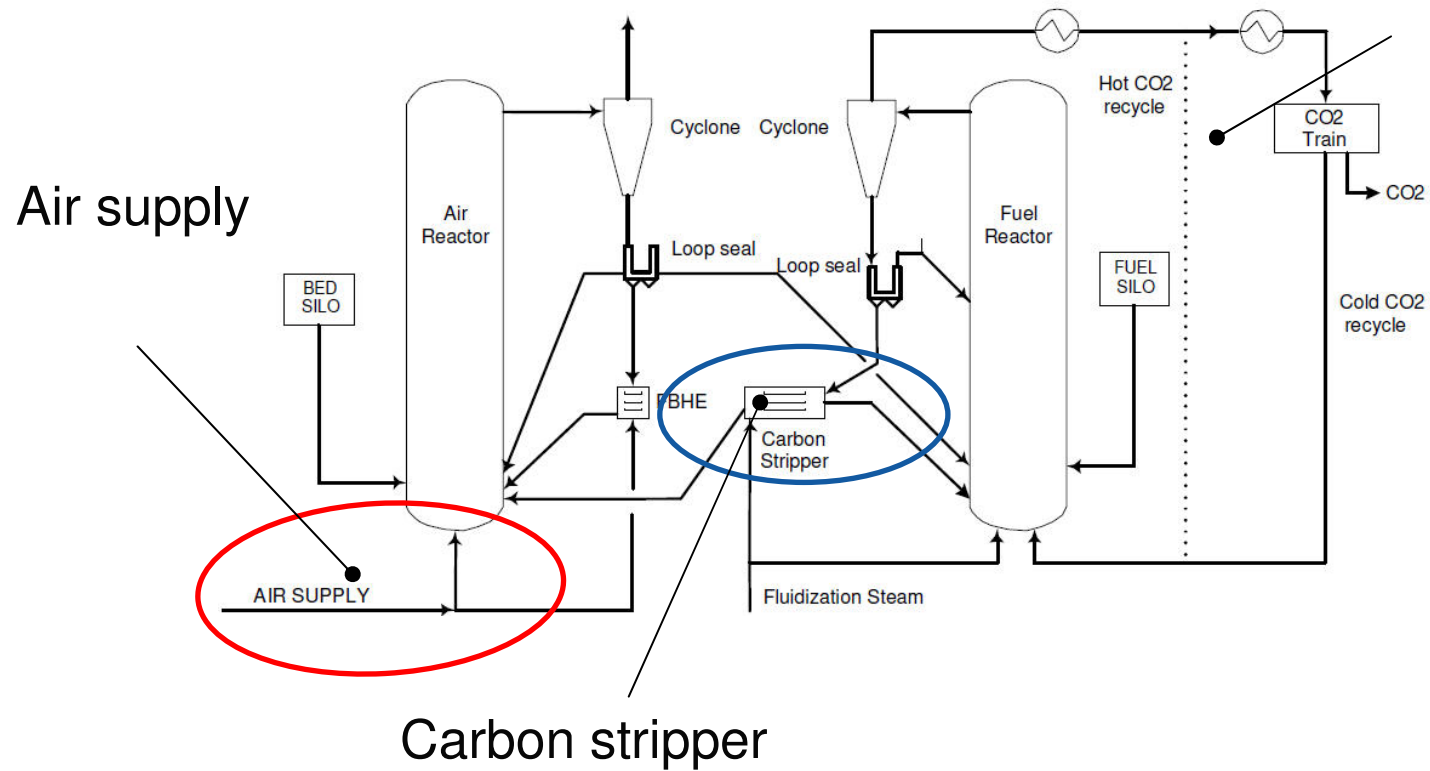

Results

Parameter Study
Net electrical efficiency vs Carbon stripper efficiency
and at different Air Reactor Lambda Value

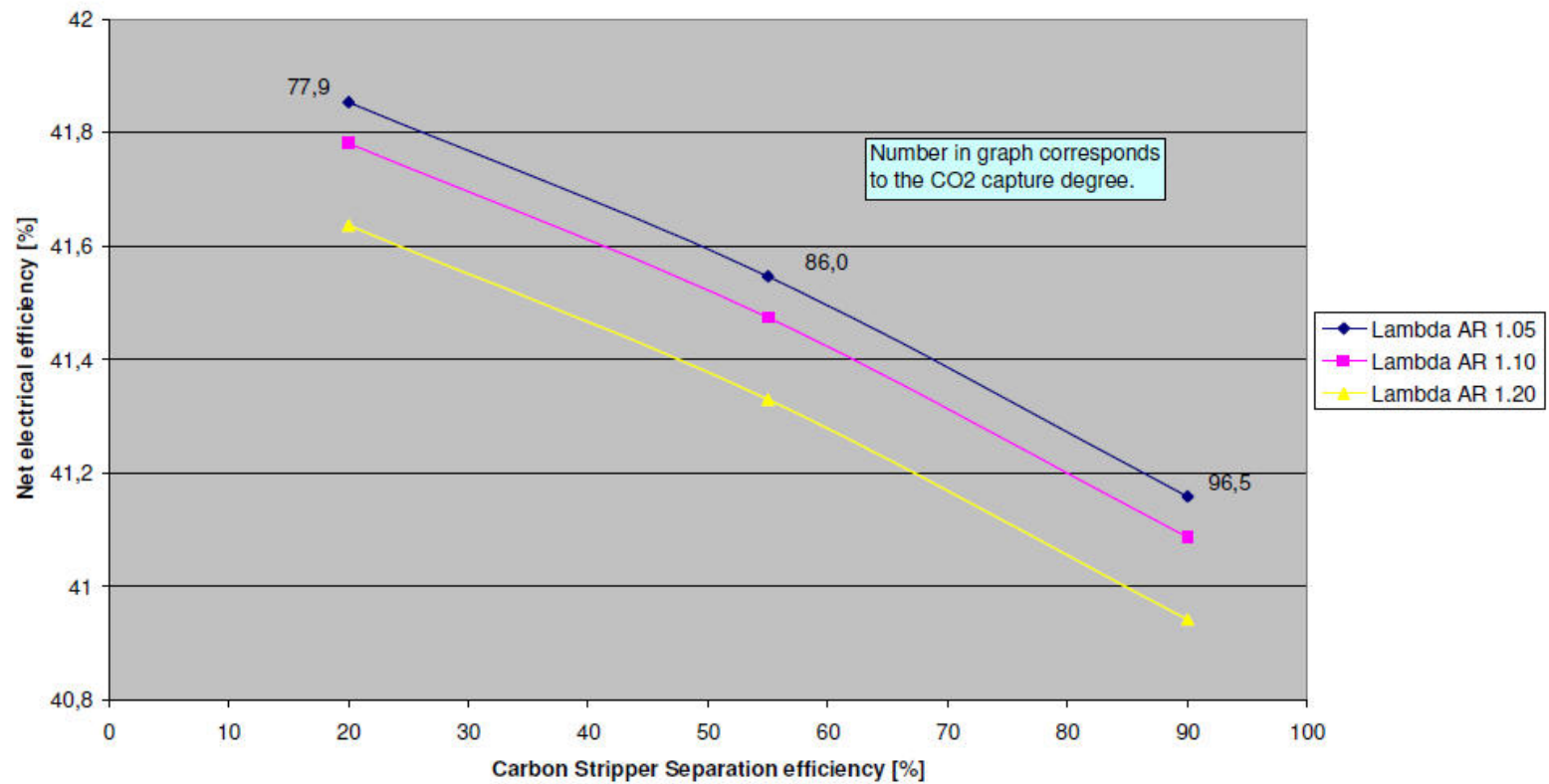

Overall conclusion

- Critical interaction between desired CO₂ capture rate and net electrical efficiency.
- Potentially a 90% CO₂ capture rate could be achieved if e.g.:
 - The carbon conversion in the fuel reactor of at least 70% corresponding to a carbon stripper efficiency of at least of 70%
 - Or, the carbon conversion is 90% corresponding to a carbon stripper efficiency of at least 15 %
- A decreased carbon stripper efficiency results in an increased net electrical efficiency. The reason is a carbon transfer into air reactor yielding an increased CO₂ emission. This results in a less power consumption of the CO₂ compression.
- The most critical parameters in terms of net electrical efficiency and CO₂ capture rate are steam demand; carbon conversion and carbon stripper efficiency

Future work

- Implement reaction kinetics and hydrodynamic function into the model
- Updating model by knowledge from the 1 MW CLC pilot

Acknowledgements

This work was carried out within the
ECLAIR project
with financial grant from the
Research Fund for Coal and Steel of the European Community.

Thank you!